

# LOW COST UNIVERSAL MOTOR CHOPPER DRIVE SYSTEM

By Ivan Skalka

Roznov System Application Laboratory

Roznov pod Radhostem, Czech Republic

## 1 INTRODUCTION

This application note describes the design of low a cost chopper motor control drive system based on the MC68HC705MC4 microcontroller, the MGP7N60E IGBT (Insulated Gate Bipolar Transistor) and the MSR860 Ultra Fast Soft Diode. This low cost single-phase power board is dedicated for universal brushed motors. The universal motor is today the most widely used motor in home appliances such as: vacuum cleaners, washers, hand tools, and food processors. The operational mode, which is used in this application, is closed loop and regulated speed. This mode requires a speed sensor on the motor shaft. Such a sensor is usually a tachometer generator. The kind of motor and its drive have a high impact on many home appliance features: like cost, size, noise and efficiency. Electronic control is usually necessary when variable speed or energy savings are required.

Microcontrollers offer the advantages of low cost and attractive design. They can operate with only few external components and reduce the energy consumption as well as cost. This circuit was designed as a very simple schematic using all features of a simple microcontroller. The microcontroller and this board may be used in a wide variety of applications.

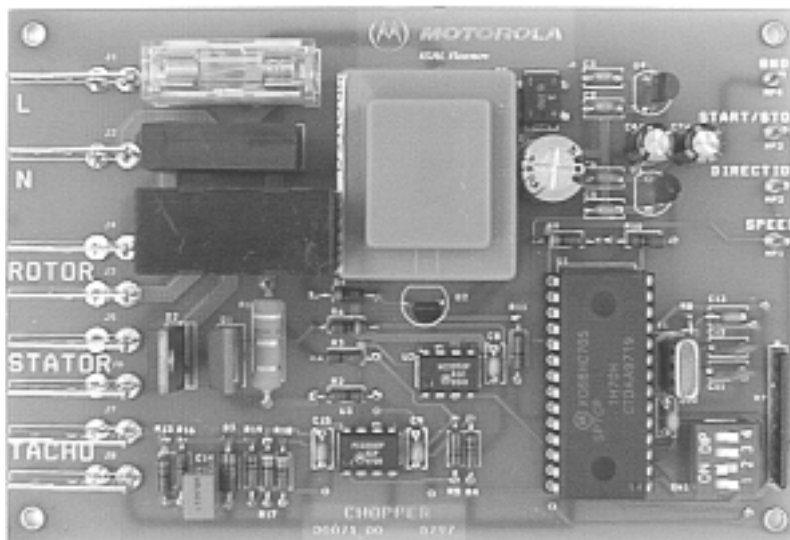

Figure 1. Low Cost Motor Control Chopper Board

The Pulse Width Modulation technique (PWM) is used to adjust the voltage applied to the motor (refer to Figure 2). Modulation of the PWM's duty cycle allows the effective voltage, seen by the motor, to be varied. The PWM technique is often termed chopper because of the chopped drive signal which is created. Compared to a phase angle drive, a chopper drive requires a more complicated power stage with an input power rectifier, a power switch, and a power fast diode. The advantage is higher efficiency, less acoustic noise and better EMC behaviour.

This application note also explains how to design the software implementation using an HC05 microcontroller. Such a low cost microcontroller is powerful enough to do whole job necessary for driving a closed loop chopper drive.

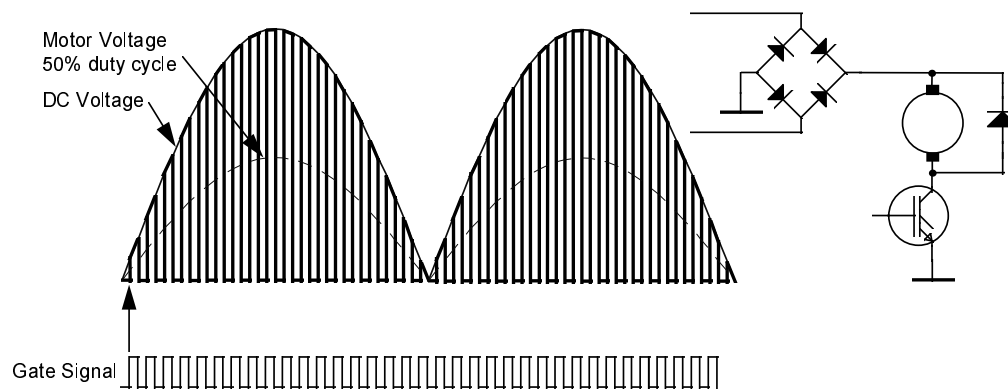

Figure 2. Pulse Width Modulation technique - Chopper

## 2 ADDED VALUE USING A MICROCONTROLLER

Compared to a poor analog solution, a microcontroller based drive shows many advantages. Some of them are listed below:

- choice between different control algorithms
- choice between any shape of speed command (acceleration and deceleration phase)
- choice between any type of tachometer
- software can make the hardware more simple
- diagnostic functions
- remote control by wire and communication protocol
- open for innovation

## 3 DEVICES

Universal motors are still used where brushes are accepted and universal motors driven by power switches are used where a low price is required. This section contains information and descriptions about all features of a suitable microcontroller, IGBT and diode.

The 68HC705MC4 is an HC05-based MCU designed for motor drive applications. General features include 3.5 k bytes of EPROM, 176 bytes of RAM, a 16-bit timer including an output compare and two input captures, 4 general-purpose I/O pins, and an SCI (UART) port in a 28-pin SOIC or a DIP package. In addition the MC4 has specific features including a 2-channel, 8-bit PWM module, a high current source port, and a 6-channel, 8-bit A/D module. The 68HC705MC4 is well suited for this application with its analog to digital converter and with its pulse width modulation block.

Motorola's series of IGBTs offered are specially designed for efficient motor drives. Switching times, saturation voltage, and short circuit capability have been optimized for these applications. The higher threshold eliminates the need for negative gate drive. With a fast switching and short circuit capability, the 'E' family of IGBTs fits well in high performance line-operated, pulse width modulated, variable speed motor drives. This family includes the single IGBTs (without copackaged free wheeling diode) in the

current range of 5 A to 20 A in a TO220 package. Some parameters of the chosen IGBT are shown in Table 1.

The MC33153 driver is specially designed to drive the gate of an IGBT used for high power applications, such as motor drive. It can be used with discrete IGBTs and IGBT modules up to 100 A. Device protection features include the choice of desaturation or overcurrent sensing plus undervoltage lockout optimized for IGBTs.

Table 1. Electrical characteristics of the MGP7N60E

Parameter	Value
Collector-Emitter Voltage $V_{CES}$	600 V Max
Collector Current Continuous $I_{C90}$	7 A Max
Collector-to-Emitter On-State Voltage ( $I_C=4$ A) $V_{CE(on)}$	2.2 V Typ
Gate Threshold Voltage $V_{GE(th)}$	6 V Typ
Turn-On/Turn-Off Delay Time $t_{d(on)}/t_{d(off)}$	59/150 ns Typ

## 4 CIRCUIT

### 4.1 Description

In Figure 3 the schematic of a chopper motor control board is shown. As can be seen, there are six major parts: the power stage, the relay, the current measurement, the circuitry for a tachometer connection, the power supply and the microcontroller. The power stage is composed of the input power bridge rectifier D1 with the capacitor C16, the power transistor Q1 and the freewheeling diode D2. There is no bulk electrolytic capacitor because of cost and size. The microcontroller can change direction of the motor with help of the relay K1.

The current measurement consists of the voltage drop resistor R1 and the differential amplifier U3A. In this part the low voltage rail-to-rail operational amplifier MC33502 is used. The MC33502 is a new device with rail-to-rail operation on both the input and output. The output can swing within 50 mV of either supply. Such a device makes it possible to build low cost circuit in order to amplify the signal from the voltage drop resistor. The only errors exist for very low currents and can be eliminated by the software.

Because this board provides the control algorithm in closed loop mode there are some devices which allow connection of a tachometer. The most frequently used tachometer has 16 poles and an output voltage of 5 V to 20 V RMS for full scale working speed. An input filter protects the operational amplifier U3B against high voltage at high speed and diode D3 protects the operational amplifier against negative voltage. The output square wave signal from the comparator is connected to pin PD7. By means of this arrangement the input capture feature of the microcontroller can be used.

The power supply produces two voltages: +12 V for the driver of the IGBT and the relay, and +5 V for the rest. The structure with the input transformer T1, the bridge rectifier D5 and the voltage regulators U4, U5 has been chosen.

The A/D convertor of the microcontroller provides the conversion of three input voltages. An external speed command is connected to pin PC4. Two other signals, PC5-motor current and PC3-mains information, are prepared for future use. Pins PC6-PC7, as reference inputs for the A/D convertor, are connected to appropriate levels of the power supply.

---

## WARNING

**This circuit is powered directly from the line. Do not touch any parts of this board. When working with such board, do not connect any computer, scope or development system. In this case it is necessary to use an isolation transformer.**

---

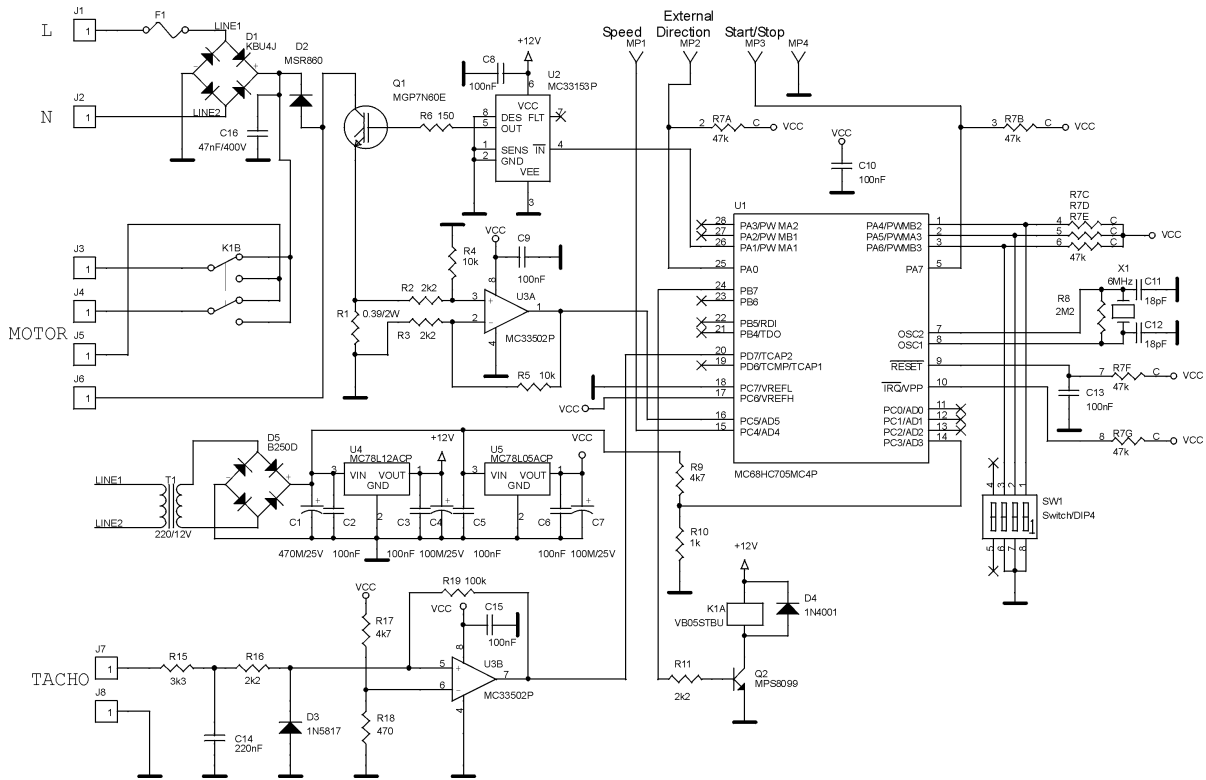

Figure 3. Low Cost Motor Control Chopper Drive

The speed command can be set externally in the range of 0 V to 5 V. A simple external control panel (refer to Figure 4.) should be linked with the chopper power stage when external commands are needed. The connectors MP1-Speed, MP2-Direction, MP3-Start/Stop and MP4-GND are provided on-board.

## WARNING

**The control panel must be isolated from the user under all possible circumstances.**

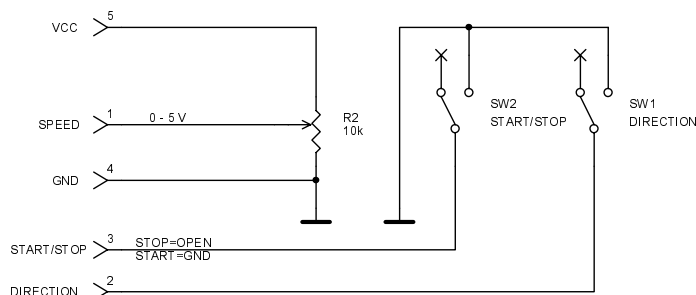

Figure 4. External Control Panel

The DIP switch SW1 allows some options of the drive's functionality and will be discussed later.

There are pullup resistors R7A-R7E on-board to provide the proper level of input signals for the microcontroller.

## 5 CONTROL ALGORITHM

The basic principle of the chopper control technique is very simple - the speed can be controlled by adjustment of the voltage applied to the motor performed by the change of the PWM duty cycle (refer to Figure 2). The universal motor is supplied in DC mode through the power stage.

Figure 5 shows a state diagram. The software consist of a Control block and some subroutines like: MAKE\_PI, RAMPE, Watch-Dog and Interrupt Services Routines. The Control Block is in fact a relatively short loop which makes a decision on which subroutines will be called. There is also a universal timing routine, which works with the HW timer and a unique register for every timed subroutine. The timing routine calculates the different between the HW timer and a particular register and, in case of coincidence with the given number (time interval), calls the appropriate subroutines. The same principle is used for all time conditions.

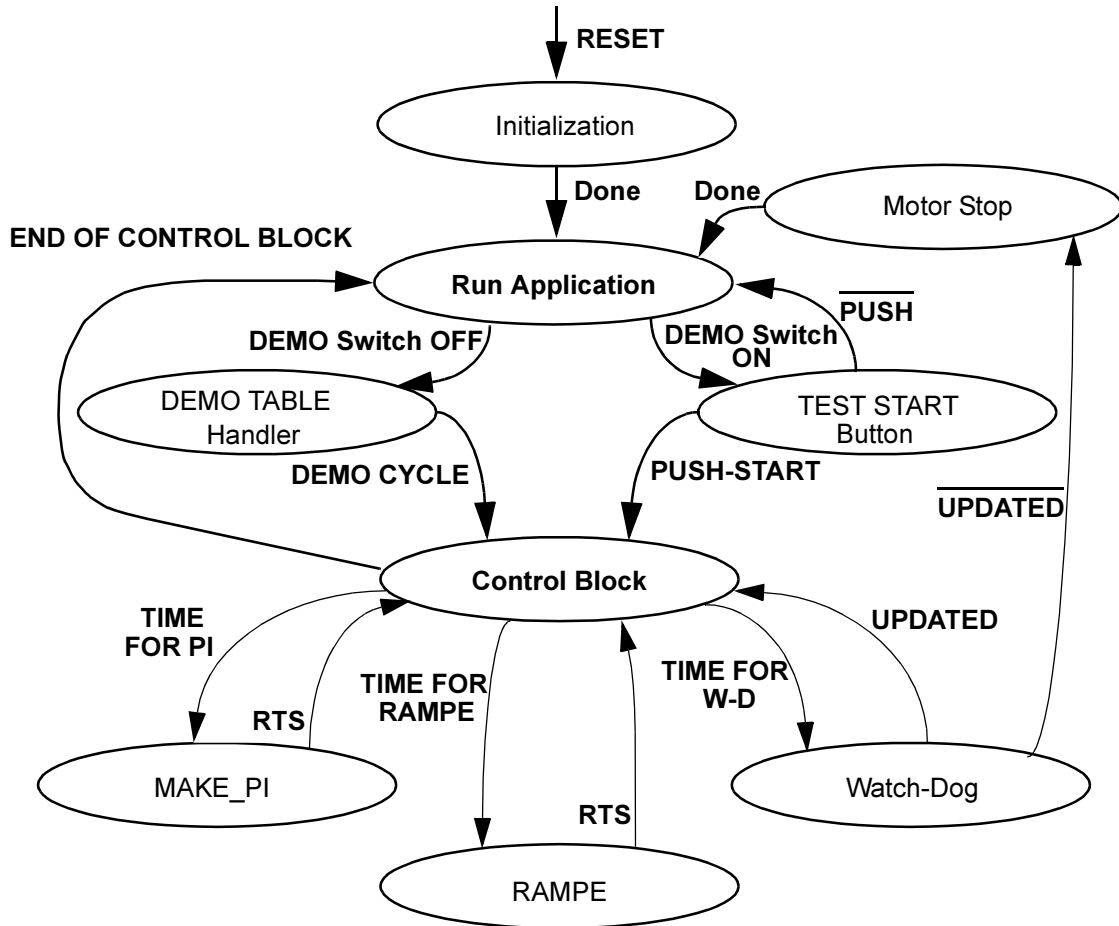

Figure 5. Program State Diagram

A DIP switch with three connected switches (refer to Figure 6) is available on the board. One of them is tested by the discussed software ("2") and two are free for customer use ("1" and "3"). The control block tests the switch number "2". This switch toggles between the "Demo mode" and the "START/STOP" mode. In the Demo mode the drive starts automatically and runs in a three step endless loop. In the START/STOP mode the external START command and the analog external speed command are necessary.



Figure 6. DIP Switch SW1

## 5.1 MAKE\_PI subroutine

The MAKE\_PI subroutine is entered when a time event occurred. The main job is the calculation of the actual speed and the calculation of the PI controller. The input value for the speed calculation is a good filtered 16-bit output value from the input capture interrupt. A 32/16 bit division is used where the 32-bit number is a constant and the 16-bit number is the output from the input capture interrupt. The constant can be calculated from the following expression:

$$\text{CONST} = N \times \text{INCAP}_{\text{MIN}}$$

Where:

CONST	= Constant for division
N	= Maximal number of result 255
INCAP <sub>MIN</sub>	= Minimal number of counts between two edges of tachometer signal (376 for 15,000 RPM and 6 MHz crystal)

$$\text{CONST} = 255 \times 376 = 95\,880 \text{ (00017688 Hex)}$$

For the PI controller the well known equation is used:

$$V = VZ\_1 + P\_CONST \times (E - EZ\_1) + I\_CONST \times E$$

Where:

V	= Actual new value
VZ_1	= V in last step
P_CONST	= proportional constant
E	= command_speed - actual_speed
EZ_1	= E in last step
I_CONST	= integration constant

The output from the PI controller is the input value for the PWM peripheral block of the microcontroller.

## 5.2 RAMPE subroutine

The RAMPE subroutine is entered when a time event occurred. This subroutine in fact changes the slope of the command speed's signal. The slope is the same for the rising and falling edges. The slope can be modified through a change in the time interval for the RAMPE subroutine.

## 5.3 Watch-dog subroutine

The Watch-dog subroutines is entered when the watch-dog register has not been updated for approximately 4 s. The input capture interrupt service routine, as a result of the running motor, takes the responsibility for the watch-dog register. By this arrangement it is possible to protect the motor when the shaft is blocked. In this case the watch-dog will turn off the IGBT and will wait for a new START command.

## 6 INTERRUPTS

The microcontroller can be interrupted in this application two different ways. The simplest interrupt is the Timer overflow interrupt. The appropriate service routine is the Timer overflow interrupt service routine (TOISR) and it enables the Input capture interrupt and starts the A/D convertor. The Input capture interrupt service routine (ICISR) is allowed to run six times every 87 ms (TOISR occurred) and it calculates an average value of the time interval between the rising edges of the tachometer signal.

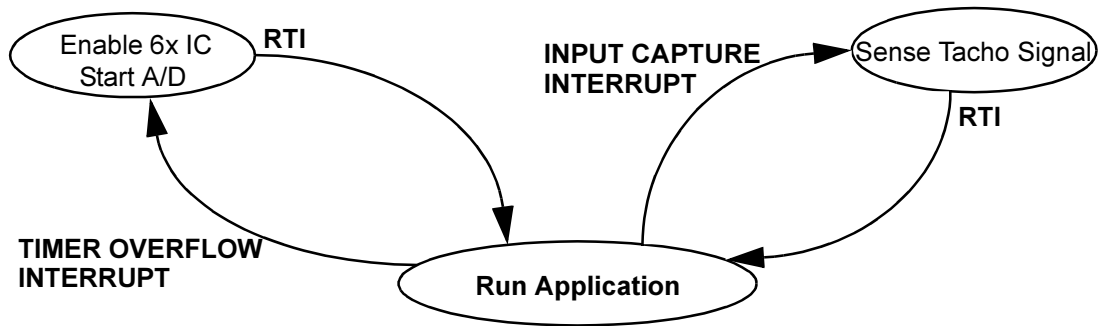

Figure 7. Interrupt Service Routines

## 7 MICROCONTROLLER USAGE

### 7.1 Total RAM & ROM used

Table 2 shows how much memory was needed to run the chopper drive. A significant part of the memory is still available.

Table 2.

Memory	Available	Used
SRAM	176Bytes	33Bytes
ROM	3.5kBytes	1.1kBytes

### 7.2 I/O use

Table 3 summarizes the use of the I/O pins. It can be seen that 9 pins are still available.

Table 3.

I/O	Available pins	Used pins	Purpose
Port A	PA0-PA7	PA0 PA1 PA4-PA6 PA7	Ext. direction PWM output DIP Switch Ext. Start
Port B	PB4-PB7	PB7	Relay
Port C	PC0-PC7	PC3 PC4 PC5 PC6-PC7	Mains Ext. speed Motor current References
Port D	PD6-PD7	PD7	Tachometer

## 8 PARTS LIST AND PCB

The list of components is listed in Table 4. and Figure 8 and Figure 9 show the PCB layout.

Table 4. Parts List

Component	Quantity	Value/Rating	Description
U1	1	-	IC, MC68HC705MC4P
U2	1	-	IC, MC33153P
U3	1	-	IC, MC33502P
U4	1	12 V, 100 mA	IC, MC78L12ACP
U5	1	5 V, 100 mA	IC, MC78L05ACP
Q1	1	8 A, 600 V	IGBT, MGP7N60E
Q2	1	80 V, 500 mA	Transistor, MPS8099
X1	1	6MHz	Resonator
D1	1	4.0 A, 600 V	Bridge Rect., KBU4J
D2	1	8.0 A, 600 V	Fast Diode MSR860
D3	1	1.0 A, 20 V	Schottky Diode 1N5817
D4	1	1.0 A, 50 V	Diode, 1N4001
D5	1	1.0 A, 500 V	Bridge Rect., B250D
R1	1	0.39 $\Omega$ , 2 W	Resistor
R2,R3,R11,R16	4	2.2 k $\Omega$ , 1/4 W	Resistor
R4,R5	2	10 k $\Omega$ , 1/4 W	Resistor
R6	1	150 $\Omega$ , 1/4 W	Resistor
R7	1	47 k $\Omega$ , 1/4 W	Resistor
R8	1	2.2 M $\Omega$ , 1/4 W	Resistor
R9, R17	2	4.7 k $\Omega$ , 1/4 W	Resistor
R10	1	1.0 k $\Omega$ , 1/4 W	Resistor
R15	1	3.3 k $\Omega$ , 1/4 W	Resistor
R18	1	470 $\Omega$ , 1/4 W	Resistor
R19	1	100 k $\Omega$ , 1/4 W	Resistor
C1	1	470 $\mu$ F, 25 V	Capacitor Electrolytic
C2,C3,C5,C6,C8,C9,C10 C13,C15	9	100 nF, 50 V	Capacitor
C4, C7	2	100 $\mu$ F, 25 V	Capacitor
C11, C12	2	18 pF, 50 V	Capacitor
C14	1	220 n, 50 VF	Capacitor
C16	1	47 nF, 400 V	Capacitor
F1	1	4 A	Fuse



Table 4. Parts List

Component	Quantity	Value/Rating	Description
T1	1	220 V/12 V, 1 VA	Transformer
K1	1	5 A, 240 VAC	Relay
J1-J8	8	-	Connector
SW1	1	-	DIP Switch
MP1-MP4	4	-	Connector

All tolerances  $\pm 10\%$  for capacitors,  $\pm 1\%$  for resistors, unless otherwise specified.

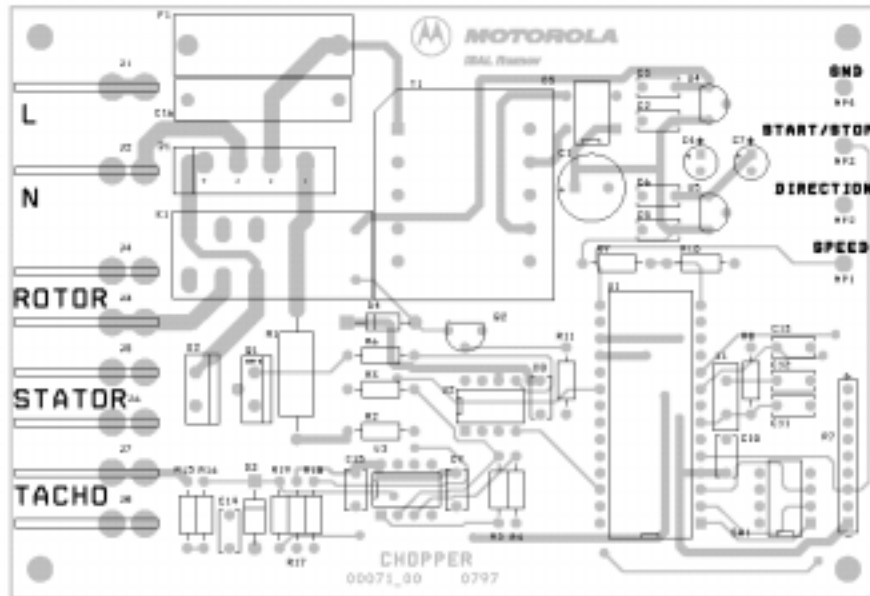

Figure 8. PCB layout Component Side

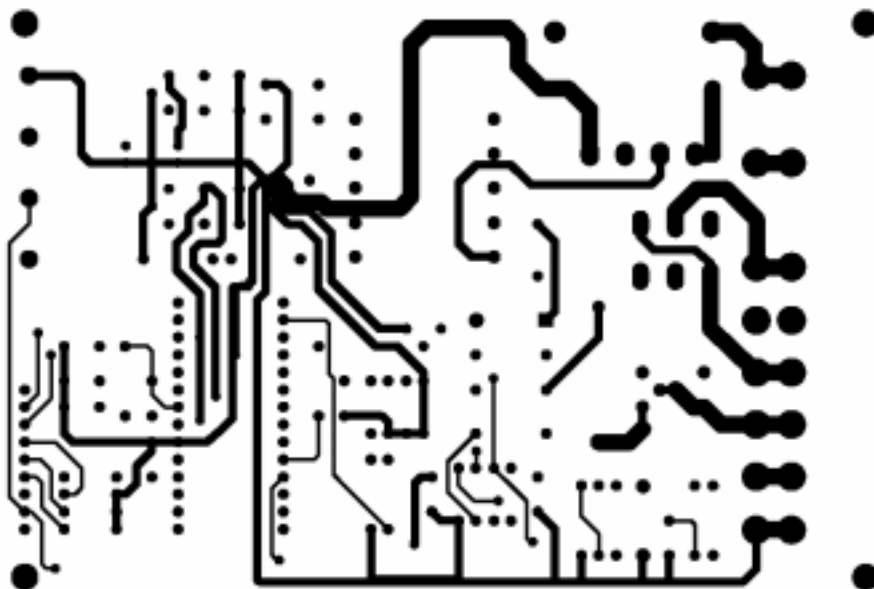

Figure 9. PCB Layout Copper Side

## Performance of the Sample Design

Input voltage:.....220 V RMS  
Input current:.....1 A RMS (without heatsink and without load)  
Motor:.....400 W with tachometer  
Demo mode:.....Automatic START, no speed reference needed  
START/STOP mode.....START-external 0 V, external speed reference 0 V to 5 V  
Speed:.....500 to 15,000 RPM

## 9 CONCLUSION

This application note describes a real application, which can be used in a low cost product. The unused memory and some performance capacity are still available for other customer's purposes. These facts make this application especially suitable for the appliance market.

---

## REFERENCES

1. MGP7N60E Data Sheet; order MGP7N60E/D
2. MC33153 Data Sheet; order MC33153/D
3. MC68HC705MC4 Data Sheet; order HC705MC4GRS/D from Motorola at <http://www.motorola.com>
4. MC33502 Data Sheet; order MC33502/D

**Notes:**

**ON Semiconductor** and  are trademarks of Semiconductor Components Industries, LLC (SCILLC). SCILLC reserves the right to make changes without further notice to any products herein. SCILLC makes no warranty, representation or guarantee regarding the suitability of its products for any particular purpose, nor does SCILLC assume any liability arising out of the application or use of any product or circuit, and specifically disclaims any and all liability, including without limitation special, consequential or incidental damages. "Typical" parameters which may be provided in SCILLC data sheets and/or specifications can and do vary in different applications and actual performance may vary over time. All operating parameters, including "Typicals" must be validated for each customer application by customer's technical experts. SCILLC does not convey any license under its patent rights nor the rights of others. SCILLC products are not designed, intended, or authorized for use as components in systems intended for surgical implant into the body, or other applications intended to support or sustain life, or for any other application in which the failure of the SCILLC product could create a situation where personal injury or death may occur. Should Buyer purchase or use SCILLC products for any such unintended or unauthorized application, Buyer shall indemnify and hold SCILLC and its officers, employees, subsidiaries, affiliates, and distributors harmless against all claims, costs, damages, and expenses, and reasonable attorney fees arising out of, directly or indirectly, any claim of personal injury or death associated with such unintended or unauthorized use, even if such claim alleges that SCILLC was negligent regarding the design or manufacture of the part. SCILLC is an Equal Opportunity/Affirmative Action Employer.

## PUBLICATION ORDERING INFORMATION

### Literature Fulfillment:

Literature Distribution Center for ON Semiconductor  
P.O. Box 5163, Denver, Colorado 80217 USA  
**Phone:** 303-675-2175 or 800-344-3860 Toll Free USA/Canada  
**Fax:** 303-675-2176 or 800-344-3867 Toll Free USA/Canada  
**Email:** ONlit@hibbertco.com

**N. American Technical Support:** 800-282-9855 Toll Free USA/Canada

**JAPAN:** ON Semiconductor, Japan Customer Focus Center  
4-32-1 Nishi-Gotanda, Shinagawa-ku, Tokyo, Japan 141-0031  
**Phone:** 81-3-5740-2700  
**Email:** r14525@onsemi.com

**ON Semiconductor Website:** <http://onsemi.com>

For additional information, please contact your local Sales Representative.

This datasheet has been download from:

[www.datasheetcatalog.com](http://www.datasheetcatalog.com)

Datasheets for electronics components.